

Cube Master Line
Triple the speed
One-third the space

BORNCUT

a cut above



Cube Master Line

The ultimate high-speed portioning solution

Designed for poultry processing, the Cube Master Line revolutionizes efficiency with industry-leading precision. This compact powerhouse delivers unmatched speed and accuracy while optimizing every inch of your operation.

- Triple the speed, one-third the space
- Seamless full-line cube cutting
- Maximum yield, uncompromised quality

Watch the Cube Master Line in action.





BC225S
Cuts and synchronizes 360 strips a minute and controls all material flow to the BC100.



Automatic transfer system that re-aligns the strips before they enter the BC100.

BC100
Cuts up to 54 cuts per second with a belt speed of 1200mm per second and can produce up to 1260 cubes per minute of 20g portions on the Cube Master line.

The shown solution is based on the best case scenario.



Triple the speed



A single line with modular flexibility

Designed for high-yield, high-throughput production, the system delivers precise portioning across a diverse range of products while maintaining exceptional quality.



One-third the space

Smaller footprint, bigger Impact

The line's advanced cutting technology ensures maximum output and integration flexibility, making it a cost-effective, space-saving solution for modern food processing facilities.



Cut out for record breaking performance

- Cutting speed: up to 3,240 cuts per minute.
- Belt speed: an unprecedented 1,200 mm per second.
- Advanced camera: 1 kHz scanning for next-level precision.



Flexible cutting angles

The knife ring allows for quick and effortless adjustment of cutting angles, with up to four predefined options (e.g., 45°, 60°, 75°, and 90°) customized to your needs. Once set, no manual adjustments are required, ensuring precision with every cut and seamless transitions between angles.

The process

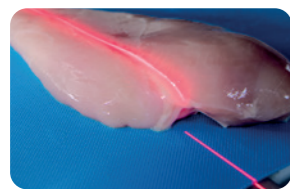

Scanning



Strip cuts



Scanning



Cube cuts

"The combination of speed, the new high-frequency scanning camera, and ultra-thin blade design allow us to cut at extreme speeds with higher accuracy than ever before. Nobody else in the market is using a 1 kHz scanning system. Competitors are at 400 Hz or lower, which means we are leagues ahead in precision."

Robert Dubravac
Head of R&D at Borncut





Centralized control, single interface

What sets our lines apart is centralized control. With this solution, everything – grading, portioning, weighing – can be managed from a single interface on the BC 225S, eliminating the need for multiple software systems. This reduces complexity, minimizes setup time and enhances operational efficiency.

High-performance computing

Multi-core industrial processing enables real-time task management and precise data handling.

Seamless integration

Single-computer control unifies portioning, grading and weighing for a streamlined workflow.

Smart automation and optimization

Reduces downtime, enhances efficiency and ensures accurate portioning for improved yield.

User-friendly and low maintenance

Intuitive interface with minimal cabling for easy operation and reduced upkeep.



Cut out for quality

Superior craftsmanship, expert design
– built for performance, engineered to last.

Modular flexibility, maximum efficiency

Customizable single and dual lane systems for optimized processing.

BC 225S Leader

Unmatched precision, unrivalled speed.

- High-speed precision cutting: delivers up to 2,170 cuts per minute with advanced servo technology for smooth, accurate portioning.
- Smart imaging and user-friendly control: 400 hz camera ensures precise cuts, while an intuitive drag-and-drop interface allows seamless production control.
- Compact and hygienic design: space-saving construction with easy-to-clean surfaces for maximum efficiency and minimal downtime.

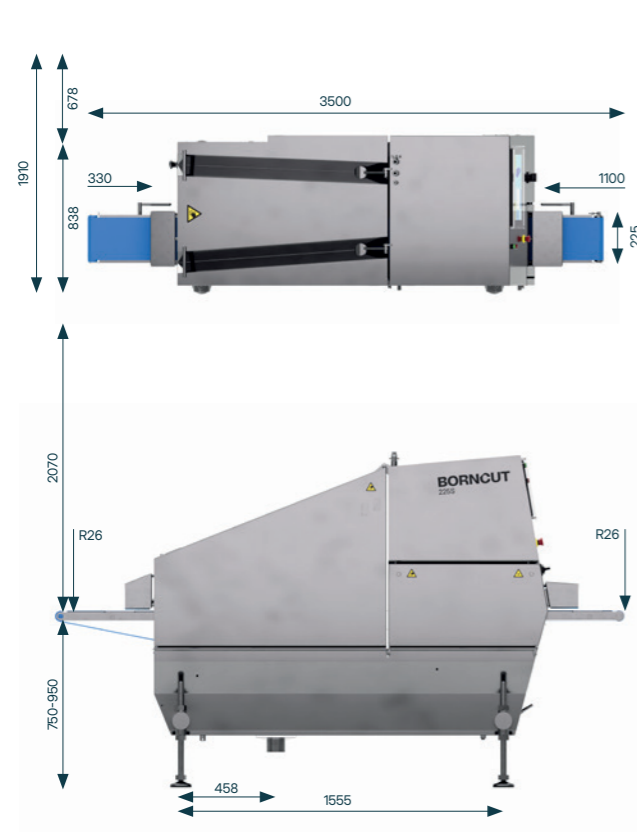

BC 100 Follower

Cutting edge 1 khz scanning technology.

- Optimized for small products: features a 100 mm belt width, allowing for reduced blade size and enhanced precision.
- Ultra-thin blade technology: utilizes a 0.7 mm blade—significantly thinner than conventional 1.5–2 mm blades—for minimal product impact and superior accuracy.
- Sustainable, space-saving design: compact build with an air-cooled motor, eliminating the need for water cooling for greater efficiency and eco-friendliness.

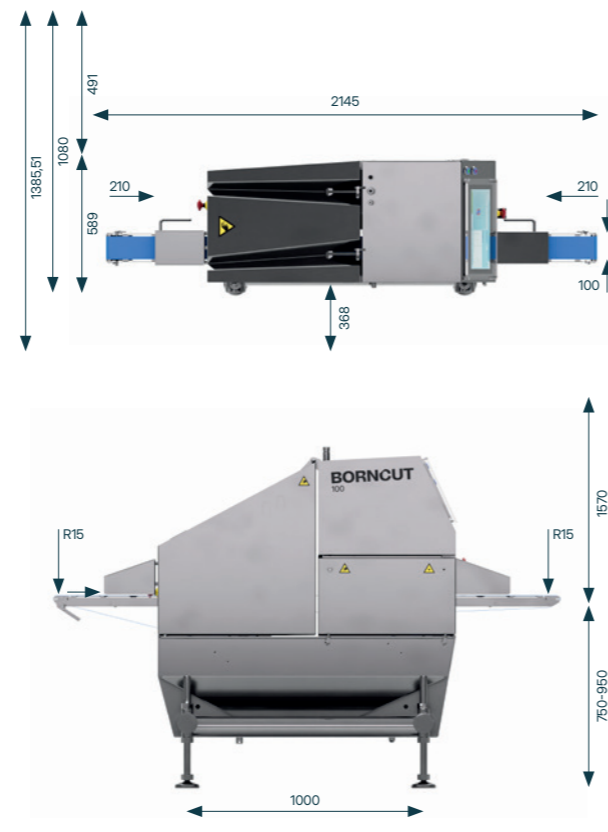

Single lane system

- Belt speed: 1,200 mm per second.
- Cutting speed: Up to 3,240 cuts per minute.
- Scanning technology: 1 kHz high-frequency camera system.
- Blade thickness: 0.7 mm ultra-thin blade for enhanced accuracy and reduced product impact.
- Machine configuration: A BC 225 cutter (Leader) and A BC 100 (Follower) in a synchronized system.

Production example – 20g cubes, single lane system

- Leader: 300 strips per minute, processing in 200 mm pockets.
- Follower: 1000 mm per second, cutting 5 strips per second into 20 cubes per second.
- Calculated total capacity: 1260 kg/hour with optimal conditions.
- Required input: 100 fillets a minute with average weight 210 g per fillet.
- Operational efficiency: 75–85% of maximum machine capacity.

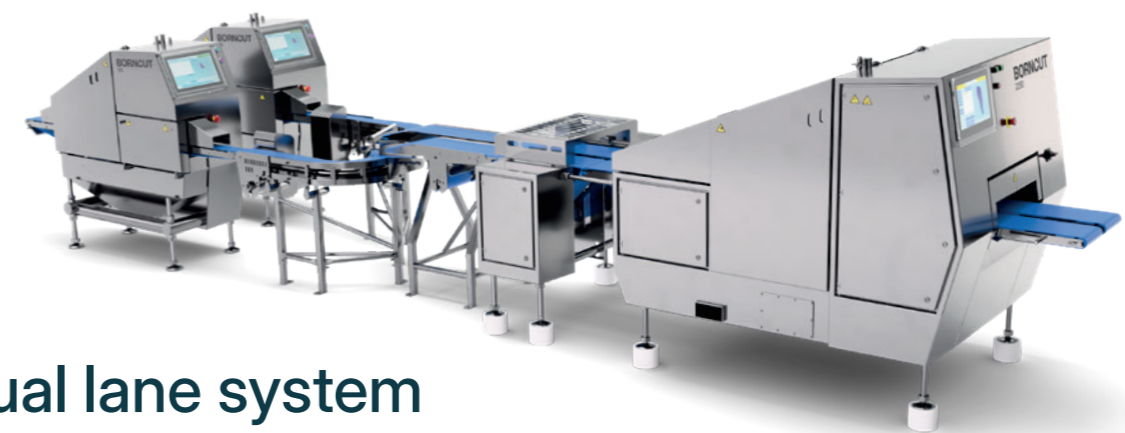

Dual lane system

Different configurations are available to accommodate various processing needs, from single to dual lanes as well as integration with existing processing systems.

Redefining Portion Cutting

Borncut combines innovation, craftsmanship and cutting-edge technology to set new standards in portion cutting. Since 2016, we've been developing some of the fastest and most precise portioning solutions, built on over 30 years of expertise.

Designed for efficiency, accuracy and seamless integration, our machines maximize yield while reducing waste. More than just technology, we're a trusted partner—delivering smart solutions and dedicated support to keep businesses ahead.

At Borncut, we don't just follow industry trends—we set them.

Lillevangsvej 6
DK-3700 Roenne
Denmark

+45 9320 6325
mail@borncut.com
borncut.com



Scan to find your
local Borncut
distributor.

BORNCUT
a cut above